



***Feasibility & Impact Study for
Generation Interconnection
Request
GEN – 2004 – 023***

***SPP Coordinated Planning
(#GEN-2004-023)***

May 2005

Summary

Pterra Consulting performed the following Study at the request of the Southwest Power Pool (SPP) for Generation Interconnection request Gen-2004-023. The request for interconnection was placed with SPP in accordance SPP's Open Access Transmission Tariff, which covers new generation interconnections on SPP's transmission system.

Pursuant to the tariff, Pterra Consulting was asked to perform a detailed Impact Study of the generation interconnection request to satisfy the expedited Impact Study Agreement executed by the requesting customer and SPP.

Pterra Consulting

Report No. R110-05

“Feasibility and Impact Study for Generation Interconnection Request GEN-2003-023”

Submitted to

The Southwest Power Pool

May 2005



4 Automation Lane, Ste.125, Albany, NY 12205 Tel: 518-724-3832 Web: www.pterra.us

‘Feasibility and Impact Study for Generation Interconnection Request GEN-2003-023’

1	Executive Summary	2
2	Project Overview	3
3	Feasibility Study	5
3.1	Interconnection Facilities	5
3.2	Power Flow Analysis.....	6
3.3	Methodology	6
3.4	Conclusion	7
4	Impact Study	8
4.1	Objective	8
4.2	Modeling of the Wind Turbines in the Load Flow	8
4.3	Modeling of the Wind Turbines for the Stability Simulation	10
4.4	Stability Models for Queued Projects.....	11
4.5	Contingencies Simulated	12
4.6	Conclusion	18
	Appendix A.....	19
	Appendix B.....	20

1 Executive Summary

<OMITTED TEXT> (Customer) has requested the Southwest Power Pool (SPP) to conduct a generator interconnection feasibility and impact study through the SPP Tariff for a 138kV interconnection for an additional 20.6 MW (the “study” project) to a previously studied 174.25 MW wind farm facility near Apache, Oklahoma. This wind farm would be interconnected to the Washita switch station owned by Western Farmers Electric Cooperative (WFEC). This would make the phase 1 and phase 2 wind farm 194.85 MW. The Customer has asked to study the project as 100% case only. The phase 1 wind farm is using 45 NEG Micon NM72 IEC I (1.65 MW). The phase 2 wind farm (120.6 MW) will now consist of 67 Vestas V80 (1.8 MW). The proposed in-service date is December 1st, 2005.

Two base cases were used in the study: 2006 summer and winter peak. Each base case was modified to include the prior queued projects with the total MW distributed across the SPP member footprint. The prior queued projects include: Gen-2003-005, Gen-2003-022, and Gen-2004-020. In the event that another request for a generation interconnection with a higher priority withdraws then this request may have to be re-evaluated to determine the local Network Constraints. The previously studied 174.25 MW project were modeled at 100% output in the base case. The study project is dispatched only into SPP member AEPW.

For the feasibility study:

Load flow analysis was conducted with and without the study project to identify the proposed generator’s impact on the local area. For the contingency tests, SPP members WFEC and AEPW are monitored. Only overloads that are greater than base case overloads + 3% are included in this report.

No interconnection facility costs are included since the study project is interconnecting the same facility as the original projects. In Table 5, a value of Available Transfer Capability (ATC) associated with any overloaded facilities is included. These values may be used by the Customer to determine lower generation capacity levels that may be installed. When transmission service associated with this interconnection is evaluated, the loading of the facilities listed in this table may be greater due to higher priority reservations. These interconnection costs do not include any cost that may be associated with short circuit analysis.

The required interconnection costs listed in Table 3 and other upgrades associated with Network Constraints listed in Table 4 do not include all costs associated with the deliverability of the energy to final customers. These costs are determined by separate studies if the Customer requests transmission service through SPP’s OASIS.

For the impact study:

Sixteen (16) contingencies were considered for the transient stability simulations which included three phase faults, as well as single phase line faults. Single phase line faults were simulated by applying a fault impedance to the positive sequence network at the fault location to represent the effect of the negative and zero sequence networks on the positive sequence network. The fault impedance was computed to give a positive sequence voltage at the specified fault location of approximately 60% of pre-fault voltage. This method is in agreement with SPP current practice. The phase 1 and phase 2 generators were modeled with voltage and frequency ride-through protection using standard settings.

Table 9 shows the list of simulated contingencies. The table also shows the fault clearing time and the time delay before re-closing for all the study contingencies. The stability simulation shows that the study plant would not degrade the stability performance of the system. Certain generating

machines are tripped during specific contingencies as summarized in Table 9, but the system remains stable and all oscillations remain well damped. The impact study finds that the study project addition shows stable performance of the SPP system for the contingencies tested on the supplied base cases.

A sensitivity study was performed to review the impact of the study project without Gen-2003-005 in the queue. The results of the sensitivity study show similar system stability performance in the case with and without Gen-2003-005 as summarized in Table 9. The prior conclusion remains valid, that the study project shows stable performance of the SPP system for the contingencies tested on the supplied bases cases.

2 Project Overview

<OMITTED TEXT> (Customer) has requested the Southwest Power Pool (SPP) to conduct a generator interconnection feasibility and impact study through the SPP Tariff for a 138kV interconnection for an additional 20.6 MW (the “study” project) to a previously studied 174.25 MW wind farm facility near Apache, Oklahoma. This wind farm would be interconnected to the Washita switch station owned by Western Farmers Electric Cooperative (WFEC). This would make the phase 1 and phase 2 wind farm 194.85 MW. The Customer has asked to study the project as 100% case only. The phase 1 wind farm is using 45 NEG Micon NM72 IEC I (1.65 MW). The phase 2 wind farm (120.6 MW) will now consist of 67 Vestas V80 (1.8 MW) as summarized in Table 1 and shown in Figure 1. The proposed in-service date is December 1st, 2005.

Description	Queued#	Interconnection point	MODEL	TOTAL MW (Feasibility Study) - note 1	TOTAL MW (Impact Study) - note 1
Phase-2 (new, study plant)	Study Plant Gen-2004-023	Apache Oklahoma, 138kV Washita (Bus #56089)	Vesta V80 Turbine 1.8 MW	20.6	19.8
Phase-2 (previously studied)	Gen-2003-004	same as above	Vesta V80 Turbine 1.8 MW	100	100.8
Phase-1	Gen-2001-026	same as above	NEG-MICON NM72 1.65 MW	74.25	74.25
Total Phase 2 (previously studied + the study plant)				120.6	120.6
Total Phase 1 and 2				194.85	194.85
Total Previously studied Project Phase 1 + 2 (old)				174.25	175.05

Note 1: For the study plant and Gen-2003-004, the MW used in the feasibility study and impact study are slightly different. In the feasibility study, the MW value of the study project represents the increment over the previously studied projects. In the impact study, the MW value represents the number of whole wind farm units (each unit sized 1.8 MW) as an increment to the previously studied Phase 2 wind farm units.

Table 1 Summary of the Phase-1 and Phase-2 Wind Generators Projects

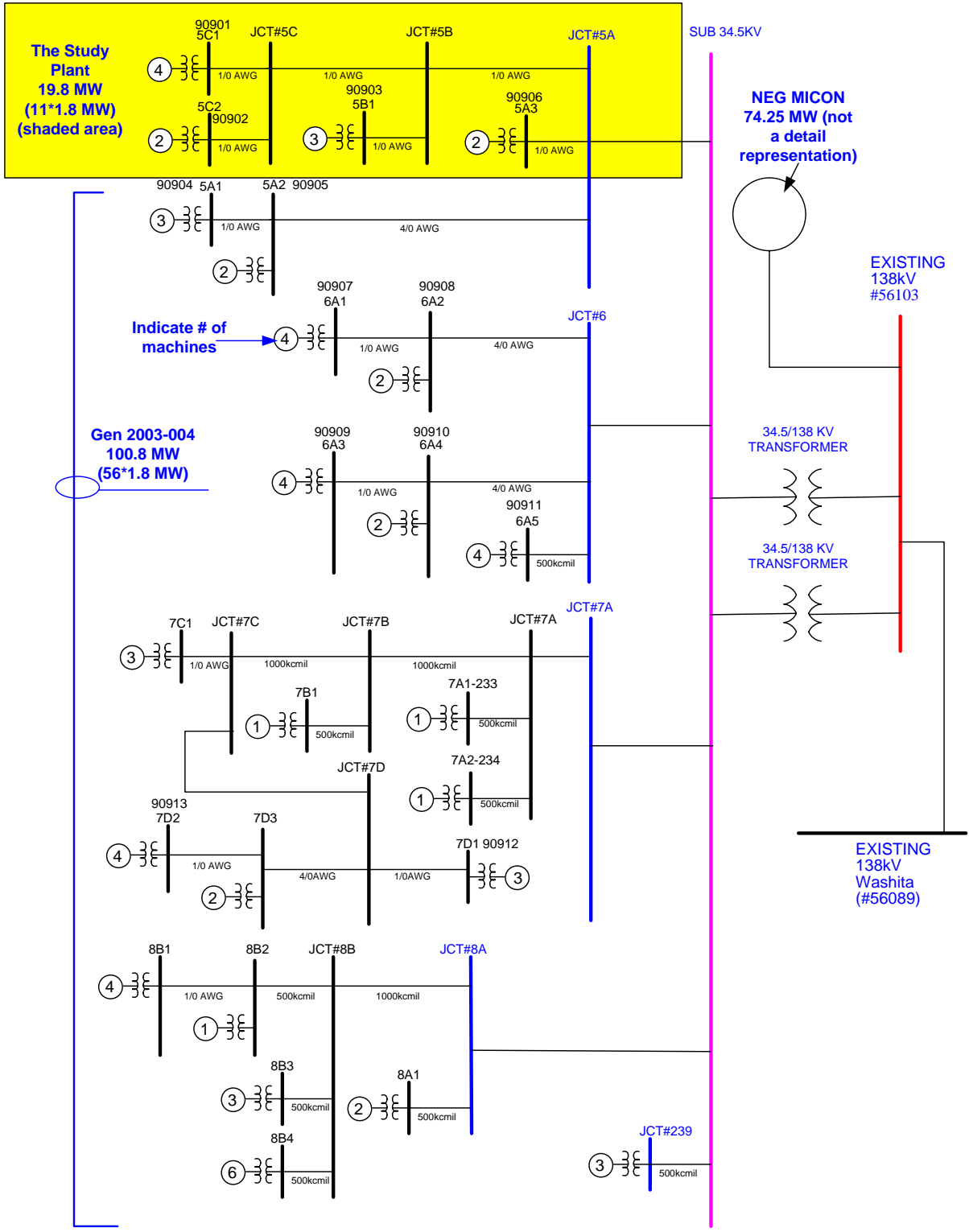

Figure 1 One Line Diagrams of the Study Plant, including Phase 1 and 2 (total of 194.85 MW)

3 Feasibility Study

3.1 Interconnection Facilities

The Feasibility Study assesses the practicality and costs involved to incorporate the study project into the SPP Transmission System. The analysis is limited to load flow analysis of the more probable contingencies within the Transmission Owner's control area and key adjacent areas.

The Feasibility Study is intended to identify attachment facilities and other direct assignment facilities needed to accept power into the grid at the interconnection receipt point. This wind farm would be interconnected to the Washita switch station owned by Western Farmers Electric Cooperative (WFEC).

No interconnection facility costs are included since the study project is interconnecting the same facility as the original projects. Other Network Constraints in the WFEC and AEPW system that were identified are listed in Table 4. These estimates will be refined during the development of the impact study based on the final designs.

Facility	Estimated Cost
Customer – 138-34.5 kV Substation facilities.	*
Total	*

*Estimates of cost to be determined by Customer.

Table 2: Direct Assignment Facilities

Facility	Estimated Cost
None	\$0
Total	\$0

Table 3: Required Interconnection Network Upgrade Facilities

Facility
None

Note: (1) Network Upgrade description will be determined at the request of the Customer.

Table 4: Network Constraints

Facility	Model and Contingency	Facility Loading ¹	ATC (MW)	Date Required
None	N/A	N/A	N/A	N/A

Table 5: Contingency Analysis Results

3.2 Power Flow Analysis

Load flow analysis was conducted with and without the study project to identify the study project's impact on the local area. In the power flow, the 20.6 MW study plant was added to the base case as new source with capacity of 20.6 MW delivering to the Washita 138 kV bus.

	Description	Queued#	TOTAL MW (Feasibility Study)
Study Plant	Phase-2 (new, study plant)	Gen-2004-023	20.6
Prior Queued Projects	Phase-2 (previously studied)	Gen-2003-004	100
	Phase-1	Gen-2001-026	74.25
	Added to base case	Gen-2003-005	120
		Gen-2003-022	120
	Gen-2004-020	27	

Table 6 Summary of the Study Plant and Queued Projects

The results of load flow analysis include power flow magnitudes under probable contingency conditions. The results of the load flow study are used to identify equipment overloads that may be encountered due to the addition of new generation. Probable contingencies comprise of single contingencies in the study area and their impact on transmission elements in the monitored area.

Two base cases were used in the study: 2006 summer and winter peak.

Each base case was modified to include the prior queued projects with the total MW redispatched across the SPP member footprint. The prior queued projects is summarized in Table 6.

The study project (20.6 MW) is dispatched only into SPP member AEPW. For the contingency tests, SPP members WFEW and AEPW are monitored. Only overloads that are greater than base case overloads + 3% are included in this report.

3.3 Methodology

The SPP criteria applied to the Feasibility Study states that: "The transmission system of the SPP region shall be planned and constructed so that the contingencies as set forth in the Criteria will meet the applicable NERC Planning Standards for System Adequacy and Security – Transmission System Table 1, and its applicable standards and measurements."

¹ % Rate B.

The analysis was conducted by assessing single contingencies in AEPW and WFEC using power flows. This is consistent with the more probable contingency testing criteria mandated by NERC and the SPP.

3.4 Conclusion

No interconnection facility costs are included since the study project is interconnecting the same facility as the original projects.

In Table 5, a value of Available Transfer Capability (ATC) associated with any overloaded facilities is included. These values may be used by the Customer to determine lower generation capacity levels that may be installed. When transmission service associated with this interconnection is evaluated, the loading of the facilities listed in this table may be greater due to higher priority reservations.

These interconnection costs do not include any cost that may be associated with short circuit analysis. The required interconnection costs listed in Table 3 and other upgrades associated with Network Constraints listed in Table 4 do not include all costs associated with the deliverability of the energy to final customers. These costs are determined by separate studies if the Customer requests transmission service through SPP's OASIS.

4 Impact Study

4.1 Objective

The objective of the impact study is to determine the impact on system stability of connecting the proposed GEN-2003-023 wind farm to SPP's 138 kV transmission system.

4.2 Modeling of the Wind Turbines in the Load Flow

In order to simplify the model of the wind farm while capturing the effect of the different impedances of cables (due to change of the conductor size and length), the wind turbines connected to the same 34.5kV feeder end points were aggregated into one equivalent unit. An equivalent impedance of that feeder is represented in the load flow database by taking the equivalent series impedances of the different feeders connecting the wind turbines. Using this approach, the wind farm was modeled with equivalent units as shown in Figure 2. The number in each circle in the diagram shows the number of individual wind turbine units that were aggregated at that bus. Appendix A shows the data used in the study for the following equipment:

1. 34.5kV feeders
2. 138kV/34.5kV transformer

The study added a 12 MVAR capacitor bank at the 34.5 kV bus (see Sub 34.5 kV in Figure 2) to maintain a unity power factor at the point of interconnection (138 kV side of the 34.5 / 138 kV transformer).

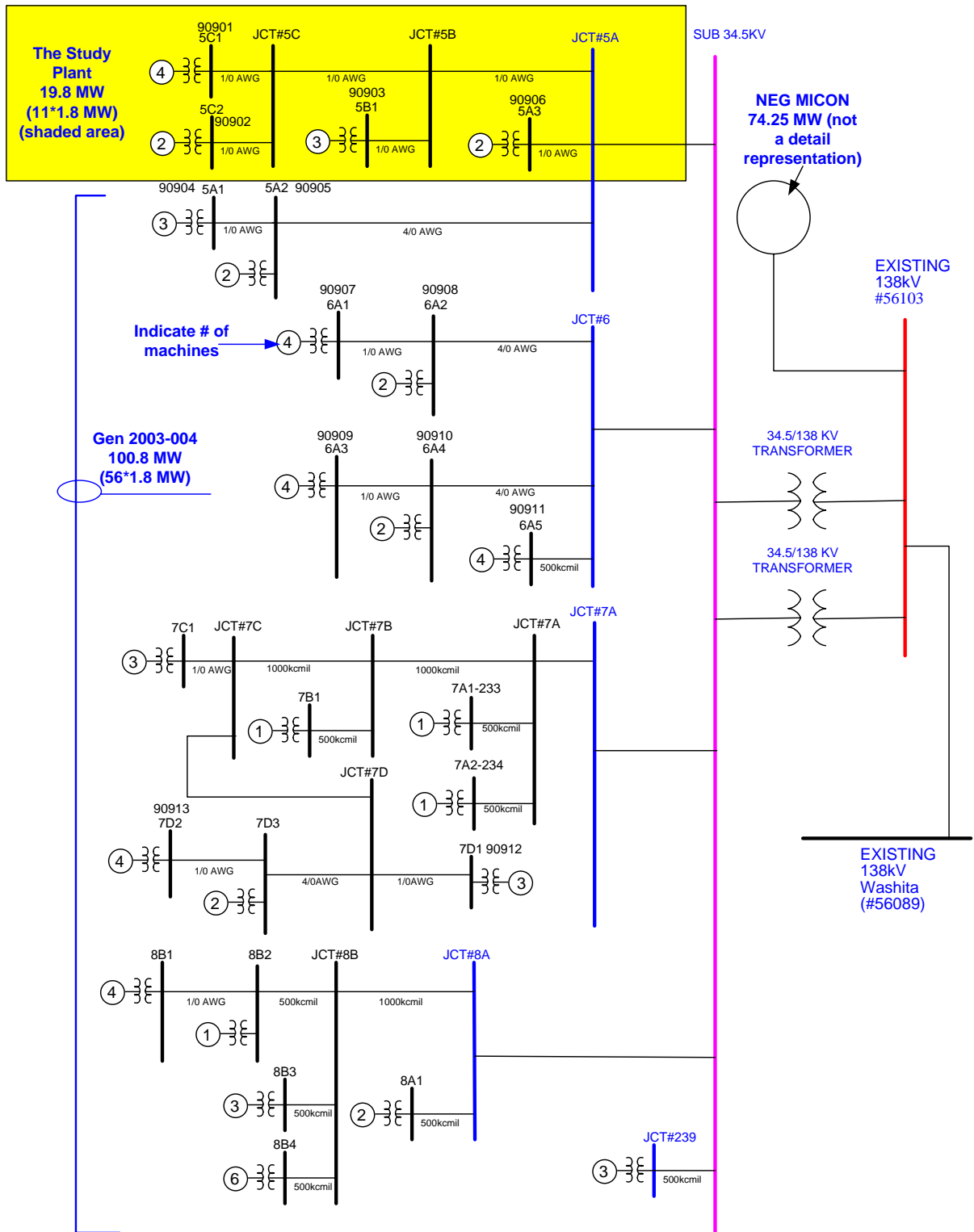

Figure 2 Wind Farm Equivalent representation in Load Flow for Stability Simulation/Impact Study

4.3 Modeling of the Wind Turbines for the Stability Simulation

Vestas V80 1.8 MW wind turbine generators were modeled for the study plant. Table 7 shows the model parameters of an equivalent generator at collector buses (90901). Note that the same models and setup are applied to all the equivalent units for the study plant (90901, 90902, 90903, and 90906).

Parameter	Value
BASE KV	0.690
WTG MBASE	2.0
TRANSFORMER MBASE	1.85
TRANSFORMER R ON TRANSFORMER BASE	0.0000
TRANSFORMER X ON TRANSFORMER BASE	0.075
GTAP	1.0
PMAX	1.8
PMIN	0.0
RA	0.0048897
LA	0.12602
LM	6.8399
R_ROT_MACH	0.004419
L1	0.18084
INERTIA	0.644
DAMPING	0.0

Table 7 Vestas 1.8 MW Wind Generator Data

For the study plant, manufacturer voltage and frequency standard protection were used. The standard voltage protection settings provided by the manufacturer are as follows:

- Voltage below 75%: 0.08 seconds, trip the generator and the power factor correction
- Voltage below 85%: 0.40 seconds, trip the generator and the power factor correction
- Voltage below 94%: 60 seconds, trip the generator and the power factor correction
- Voltage 94% to 110%: continuous
- Voltage above 110%: 60 second, trip the generator and the power factor correction
- Voltage above 111%: 0.08 second, trip the power factor correction
- Voltage above 113.5%: 0.2 second, trip the generator and the power factor correction
- Voltage above 120%: 0.08 second, trip the generator and the power factor correction

The frequency protection settings provided by the manufacturer are as following:

- Monitor bus: collector bus
- Frequency below 57.0 Hz: 0.2 seconds, trip the generator and the power factor correction
- Frequency 57.0 to 62.0 Hz: continuous
- Frequency above 62.0 Hz: 0.2 seconds, trip the generator and the power factor correction

4.4 Stability Models for Queued Projects

There are several queued projects which were added to the stability base case as summarized in Table 8:

	Description	Queued#	TOTAL MW (<u>Impact Study</u>)
Study Plant	Phase-2 (new, study plant)	Gen-2004-023	19.8
Prior Queued Projects	Phase-2 (previously studied)	Gen-2003-004	100.8
	Phase-1	Gen-2001-026	74.25
	Added to base case	Gen-2003-005	120
		Gen-2003-022	120
		Gen-2004-020	27

Table 8 Summary of Prior Queued projects

4.5 Contingencies Simulated

Sixteen (16) contingencies were considered for the transient stability simulations which included three phase faults, as well as single phase line faults, at the locations defined by SPP. Single-phase line faults were simulated by applying a fault impedance to the positive sequence network at the fault location to represent the effect of the negative and zero sequence networks on the positive sequence network. The fault impedance was computed to give a positive sequence voltage at the specified fault location of approximately 60% of pre-fault voltage. This method is in agreement with SPP current practice. Table 9 shows the list of simulated contingencies. The table also shows the fault clearing time and the time delay before re-closing for all the study contingencies.

Figure 3 provides a diagram to better visualize the fault locations in the Stability Simulations.

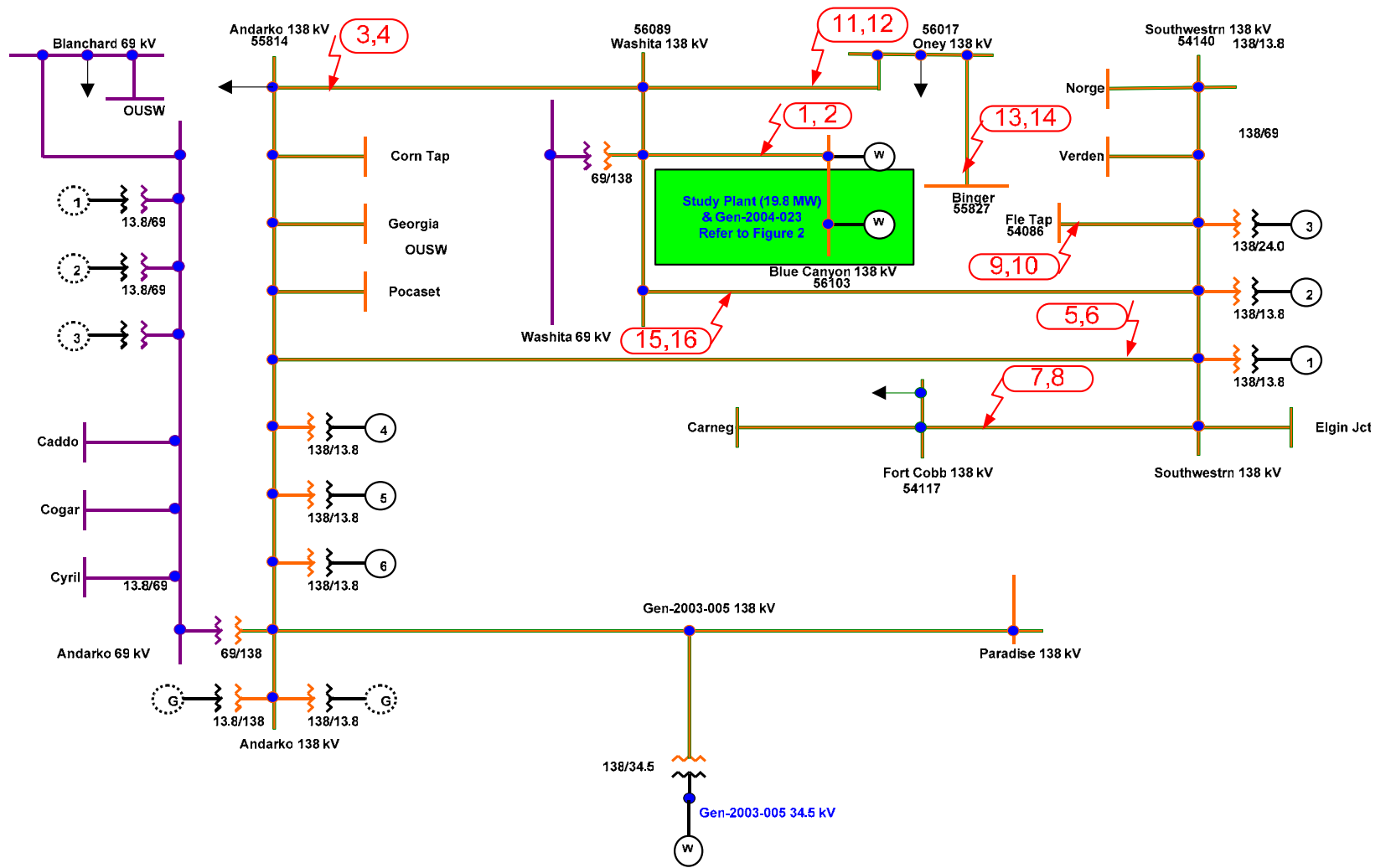

Figure 3 Fault Locations for Contingencies Tested in Stability Simulations

Table 9 List of Contingencies and Results Summary for Impact Study

Units Trip Legend

- A = 2004-023 Study Plant (Vestas 1.8 MW, total 19.8 MW) & 2003-004 (Vestas 1.8 MW, total 100.8 MW)
- B = 2003-005 (GE 1.5 MW, total 120 MW)
- C = Phase 1 (NEG Micon 1.65 MW, total 74.25 MW)
- D = 2003-022 & 2004-020 (GE 1.5 MW, total 147 MW)

<i>Cont. No.</i>	<i>Cont.Name</i>	<i>Description</i>	<i>Case-1: 2006 Summer Peak (With Gen-2003-005)</i>	<i>Case-2: 2006 Summer Peak (Without Gen-2003-005)</i>	<i>Case-3: 2006 Winter Peak (With Gen-2003-005)</i>	<i>Case-4: 2006 Winter Peak (Without Gen-2003-005)</i>
1	FLT13PH	3 Phase Fault on the Washita (56089) – Wind Farm (56103), 138kV line, near the Wind Farm. a. Apply Fault at the Wind Farm Bus (56103). b. Clear Fault after 5 cycles by removing the line from 56089-56103. c. Wait 20 cycles, and then re-close the line in (b) into the fault. d. Leave fault on for 5 cycles, then trip the line in (b) and remove fault.	Stable (Trip A+ C)	Stable (Trip A+ C)	Stable (Trip A+ C)	Stable (Trip A+ C)
2	FLT21PH	<i>Single phase fault and sequence like Cont. No. 1</i>	Stable (Trip A+ C)	Stable (Trip A+ C)	Stable (Trip A+ C)	Stable (Trip A+ C)
3	FLT33PH	3-phase fault Fault on the Washita (56089) – Anadarko (55814), 138kV line, near Anadarko. a. Apply fault at the Anadarko bus (55814). b. Clear fault after 5 cycles by removing the line from 56088-55814. c. Wait 20 cycles, and then re-close the line in (b) into the	Stable (Trip A+B+ C)	Stable (Trip A+ C)	Stable (Trip A+B+ C)	Stable (Trip A+ C)

Cont. No.	Cont.Name	Description	<u>Case-1: 2006 Summer Peak (With Gen-2003-005)</u>	<u>Case-2: 2006 Summer Peak (Without Gen-2003-005)</u>	<u>Case-3: 2006 Winter Peak (With Gen-2003-005)</u>	<u>Case-4: 2006 Winter Peak (Without Gen-2003-005)</u>
		fault. d. Leave fault on for 5 cycles, then trip the line in (b) and remove fault.				
4	FLT41PH	<i>Single phase fault and sequence like Cont. No. 3</i>	Stable	Stable	Stable	Stable
5	FLT53PH	Three phase fault on the Anadarko (55814) – Southwester Station (54140) 138 kV line, near Southwester Station. a. Apply fault at the Southwester Station bus (54140). b. Clear fault after 5 cycles by removing the line from 55814 – 54140. c. Wait 20 cycles, and then re-close line in (b) into the fault. d. Leave fault on for 5 cycles, then trip the line in (b) and remove fault.	Stable (Trip A+B+ C)	Stable (Trip A+ C)	Stable (Trip A+ B+C)	Stable (Trip A+ C)
6	FLT61PH	<i>Single phase fault and sequence like Cont. No. 5</i>	Stable	Stable	Stable	Stable
7	FLT73PH	3-phase Fault Fault on the Fort Cobb (54117) – Southwester Station (54140) 115 kV line, near Fort Cobb a. Apply fault at the Fort Cobb (54117). b. Clear fault after 5 cycles by removing the line from 54117 – 54140) c. Wait 20 cycles, and then re-close lines in (b) into the fault. d. Leave fault on for 5 cycles, then trip the line in (b) and remove fault.	Stable (Trip A+ C)	Stable (Trip A+ C)	Stable	Stable
8	FLT81PH	<i>Single phase fault and sequence like Cont. No. 7</i>	Stable	Stable	Stable	Stable

Cont. No.	Cont.Name	Description	<u>Case-1: 2006 Summer Peak (With Gen-2003-005)</u>	<u>Case-2: 2006 Summer Peak (Without Gen-2003-005)</u>	<u>Case-3: 2006 Winter Peak (With Gen-2003-005)</u>	<u>Case-4: 2006 Winter Peak (Without Gen-2003-005)</u>
9	FLT93PH	<p>FLT93PH-3-phase Fault <i>Fault on the Fletcher tap (54086) – Southwester Station (54140) 138 kV line, near Fletcher tap</i></p> <p>a. Apply fault at the Fletcher tap (54086). b. Clear fault after 5 cycles by removing the line from 54086 to 54140. c. Wait 30 cycles, and then re-close the line in (b) and remove fault. d. Leave fault on for 5 cycles, then trip the line in (b) and remove fault.</p>	Stable	Stable	Stable	Stable
10	FLT101PH	<i>Single phase fault and sequence like Cont. No. 9</i>	Stable	Stable	Stable	Stable
11	FLT113PH	<p>FLT113PH – 3-phase fault Fault on the Washita (56089) – Oney (56017) 138kV line, near Oney.</p> <p>a. Apply fault at the Oney bus (56017). b. Clear fault after 5 cycles by removing line from 56089 – 56017. c. Wait 20 cycles, and then re-close line in (b) into the fault. d. Leave fault on for 5 cycles, then trip the line in (b) and remove fault.</p>	Stable (Trip A + C)	Stable (Trip A + C)	Stable (Trip A + C)	Stable (Trip A + C)
12	FLT121PH	<i>Single phase fault and sequence like Cont. No. 11</i>	Stable	Stable	Stable	Stable
13	FLT133PH	<p>3-phase fault Fault on the Oney (56017) – Binger Niject (55827) 138 kV line, near Binger Niject</p> <p>a. Apply fault at the Binger Niject bus (55827). b. Clear fault after 5 cycles by removing line from 56017 –</p>	Stable	Stable	Stable (Trip A + C)	Stable (Trip A + C)

<i>Cont. No.</i>	<i>Cont.Name</i>	<i>Description</i>	<i><u>Case-1: 2006 Summer Peak (With Gen-2003-005)</u></i>	<i><u>Case-2: 2006 Summer Peak (Without Gen-2003-005)</u></i>	<i><u>Case-3: 2006 Winter Peak (With Gen-2003-005)</u></i>	<i><u>Case-4: 2006 Winter Peak (Without Gen-2003-005)</u></i>
		55827. c. Wait 20 cycles, and then re-close line in (b) into the fault. d. Leave fault on for 5 cycles, then trip the line in (b) and remove fault.				
14	FLT141PH	<i>Single phase fault and sequence like Cont. No. 13</i>	Stable	Stable	Stable	Stable
15	FLT153PH	FLT153PH-3-phase Fault <i>Fault on the NEW line Washita (56089) – Southwester Station (54140) 138 kV line, near Washita.</i> a. <i>Apply fault at the Washita (56089).</i> b. <i>Clear fault after 5 cycles by removing the line from 56089 to 54140.</i> c. <i>Wait 30 cycles, and then re-close the line in (b) and remove fault.</i> d. <i>Leave fault on for 5 cycles, then trip the line in (b) and remove fault.</i>	Stable	Stable	Stable	Stable
16	FLT161PH	<i>Single phase fault and sequence like Cont. No. 15</i>	Stable	Stable	Stable	Stable

4.6 Conclusion

The stability simulation shows that the study plant would not degrade the stability performance of the system. Certain generating machines are tripped during specific contingencies as summarized in Table 9, but the system remains stable and all oscillations remain well damped. The impact study finds that the proposed project addition shows stable performance of the SPP system for the contingencies tested on the supplied base cases.

A sensitivity study was performed to review the impact of the study project without Gen-2003-005 in the queue. The results of the sensitivity study show similar system stability performance in the case with and without Gen-2003-005 as summarized in Table 9. The prior conclusion remains valid, that the study project shows stable performance of the SPP system for the contingencies tested on the supplied bases cases.

Appendix A

Wind Turbine Feeder

Gen-2003-004 & Gen-2004-023 Electrical Feeder Data

CABLE RUN	Cable Size	Cable Length (ft)	Ohms	Ohms	Siemens	Ohms	Ohms
			R1	X1	Y1	R0	X0
208-207	1/0 AWG	705	0.1495	0.0388	0.0000099	0.3842	0.1882
207-206	1/0 AWG	755	0.1601	0.0415	0.0000106	0.4115	0.2016
206-205	1/0 AWG	1130	0.2396	0.0622	0.0000158	0.6159	0.3017
205-JCT#5C	1/0 AWG	870	0.1844	0.0479	0.0000122	0.4742	0.2323
203-204	1/0 AWG	705	0.1495	0.0388	0.0000099	0.3842	0.1882
204-JCT#5C	1/0 AWG	545	0.1155	0.0300	0.0000076	0.2970	0.1455
JCT#5C-JCT#5B	4/0 AWG	2145	0.2295	0.1051	0.0000386	0.7143	0.2424
240-241	1/0 AWG	670	0.1420	0.0369	0.0000094	0.3652	0.1789
241-242	1/0 AWG	750	0.1590	0.0413	0.0000105	0.4088	0.2003
242-JCT#5B	1/0 AWG	130	0.0276	0.0072	0.0000018	0.0709	0.0347
JCT#5B-JCT#5A	500kcmil	4510	0.2120	0.1894	0.0001082	0.7126	0.1984
243-244	1/0 AWG	690	0.1463	0.0380	0.0000097	0.3761	0.1842
244-245	1/0 AWG	1220	0.2586	0.0671	0.0000171	0.6649	0.3257
245-246	1/0 AWG	970	0.2056	0.0534	0.0000136	0.5287	0.2590
246-247	4/0 AWG	925	0.0990	0.0453	0.0000167	0.3080	0.1045
247-JCT#5A	4/0 AWG	260	0.0278	0.0127	0.0000047	0.0866	0.0294
224-225	1/0 AWG	1195	0.2533	0.0657	0.0000167	0.6513	0.3191
225-JCT#5A	1/0 AWG	2565	0.5438	0.1411	0.0000359	1.3979	0.6849
JCT#5A-SUB	1000kcmil	16170	0.4528	0.5983	0.0005013	1.2936	0.4204
226-227	1/0 AWG	825	0.1749	0.0454	0.0000116	0.4496	0.2203
227-228	1/0 AWG	655	0.1389	0.0360	0.0000092	0.3570	0.1749
228-229	1/0 AWG	710	0.1505	0.0391	0.0000099	0.3870	0.1896
229-230	1/0 AWG	845	0.1791	0.0465	0.0000118	0.4605	0.2256
230-231	4/0 AWG	1965	0.2103	0.0963	0.0000354	0.6543	0.2220
231-JCT#6	4/0 AWG	3500	0.3745	0.1715	0.0000630	1.1655	0.3955
248-249	1/0 AWG	715	0.1516	0.0393	0.0000100	0.3897	0.1909
249-250	1/0 AWG	675	0.1431	0.0371	0.0000095	0.3679	0.1802
250-251	1/0 AWG	1550	0.3286	0.0853	0.0000217	0.8448	0.4139
251-252	1/0 AWG	760	0.1611	0.0418	0.0000106	0.4142	0.2029
252-253	4/0 AWG	695	0.0744	0.0341	0.0000125	0.2314	0.0785
253-JCT#6	4/0 AWG	4740	0.5072	0.2323	0.0000853	1.5784	0.5356
254-255	500kcmil	675	0.0317	0.0284	0.0000162	0.1067	0.0297
255-256	500kcmil	710	0.0334	0.0298	0.0000170	0.1122	0.0312
256-257	500kcmil	1005	0.0472	0.0422	0.0000241	0.1588	0.0442
257-JCT#6	500kcmil	345	0.0162	0.0145	0.0000083	0.0545	0.0152
JCT#6-SUB	1000kcmil	6010	0.1683	0.2224	0.0001863	0.4808	0.1563
202-201	1/0 AWG	645	0.1367	0.0355	0.0000090	0.3515	0.1722
201-215	1/0 AWG	3005	0.6371	0.1653	0.0000421	1.6377	0.8023
215-216	1/0 AWG	1125	0.2385	0.0619	0.0000158	0.6131	0.3004
216-JCT#7D	1/0 AWG	1620	0.3434	0.0891	0.0000227	0.8829	0.4325
209-210	1/0 AWG	640	0.1357	0.0352	0.0000090	0.3488	0.1709
210-211	1/0 AWG	740	0.1569	0.0407	0.0000104	0.4033	0.1976
211-212	1/0 AWG	765	0.1622	0.0421	0.0000107	0.4169	0.2043
212-213	1/0 AWG	725	0.1537	0.0399	0.0000102	0.3951	0.1936
213-214	4/0 AWG	630	0.0674	0.0309	0.0000113	0.2098	0.0712
214-JCT#7D	4/0 AWG	1135	0.1214	0.0556	0.0000204	0.3780	0.1283

Gen-2003-004 & Gen-2004-023 Electrical Feeder Data

CABLE RUN	Cable Size	Cable Length (ft)	Ohms	Ohms	Siemens	Ohms	Ohms
			R1	X1	Y1	R0	X0
JCT#7D-JCT#7C	500kcmil	1265	0.0595	0.0531	0.0000304	0.1999	0.0557
219-218	1/0 AWG	730	0.1548	0.0402	0.0000102	0.3979	0.1949
218-217	1/0 AWG	1295	0.2745	0.0712	0.0000181	0.7058	0.3458
217-JCT#7C	1/0 AWG	2265	0.4802	0.1246	0.0000317	1.2344	0.6048
JCT#7C-JCT#7B	1000kcmil	2115	0.0592	0.0783	0.0000656	0.1692	0.0550
232-JCT#7B	500kcmil	85	0.0040	0.0036	0.0000020	0.0134	0.0037
JCT#7B-JCT#7A	1000kcmil	1010	0.0283	0.0374	0.0000313	0.0808	0.0263
234-JCT#7A	500kcmil	1295	0.0609	0.0544	0.0000311	0.2046	0.0570
233-JCT#7A	500kcmil	890	0.0418	0.0374	0.0000214	0.1406	0.0392
JCT#7A-SUB	1000kcmil	7700	0.2156	0.2849	0.0002387	0.6160	0.2002
220-221	1/0 AWG	725	0.1537	0.0399	0.0000102	0.3951	0.1936
221-222	1/0 AWG	625	0.1325	0.0344	0.0000088	0.3406	0.1669
222-235	1/0 AWG	2925	0.6201	0.1609	0.0000410	1.5941	0.7810
235-258	1/0 AWG	2940	0.6233	0.1617	0.0000412	1.6023	0.7850
258-JCT#8B	500kcmil	1130	0.0531	0.0475	0.0000271	0.1785	0.0497
261-260	500kcmil	845	0.0397	0.0355	0.0000203	0.1335	0.0372
260-259	500kcmil	710	0.0334	0.0298	0.0000170	0.1122	0.0312
259-JCT#8B	500kcmil	95	0.0045	0.0040	0.0000023	0.0150	0.0042
267-266	500kcmil	795	0.0374	0.0334	0.0000191	0.1256	0.0350
266-265	500kcmil	695	0.0327	0.0292	0.0000167	0.1098	0.0306
265-264	500kcmil	660	0.0310	0.0277	0.0000158	0.1043	0.0290
264-263	500kcmil	665	0.0313	0.0279	0.0000160	0.1051	0.0293
263-262	500kcmil	795	0.0374	0.0334	0.0000191	0.1256	0.0350
262-JCT#8B	500kcmil	2205	0.1036	0.0926	0.0000529	0.3484	0.0970
JCT#8B-JCT#8A	1000kcmil	2430	0.0680	0.0899	0.0000753	0.1944	0.0632
237-236	500kcmil	635	0.0298	0.0267	0.0000152	0.1003	0.0279
236-JCT#8A	500kcmil	740	0.0348	0.0311	0.0000178	0.1169	0.0326
JCT#8A-SUB	1000kcmil	2205	0.0617	0.0816	0.0000684	0.1764	0.0573
223-238	500kcmil	1795	0.0844	0.0754	0.0000431	0.2836	0.0790
238-239	500kcmil	680	0.0320	0.0286	0.0000163	0.1074	0.0299
239-SUB	500kcmil	3235	0.1520	0.1359	0.0000776	0.5111	0.1423

Appendix B

Sample Plots:

- 2006 Summer Peak, Contingency 1, with Gen-2003-005
- 2006 Summer Peak, Contingency 6, without Gen-2003-005



2004 SERIES, NERC/MMWG BASE CASE LIBRARY
 2006 SUMMER, FINAL; FOR DYN
 CASE1 : SUMMER PEAK
 STUDY PLANT (GEN04-023) & GEN03-005 IN-SERVICE
 FILE: Z:\common drive\sample plot\Casel-output\1_FLT13PH.OUT

FRI, MAY 13 2005 17:27
 1B-MC ANGLE WIND

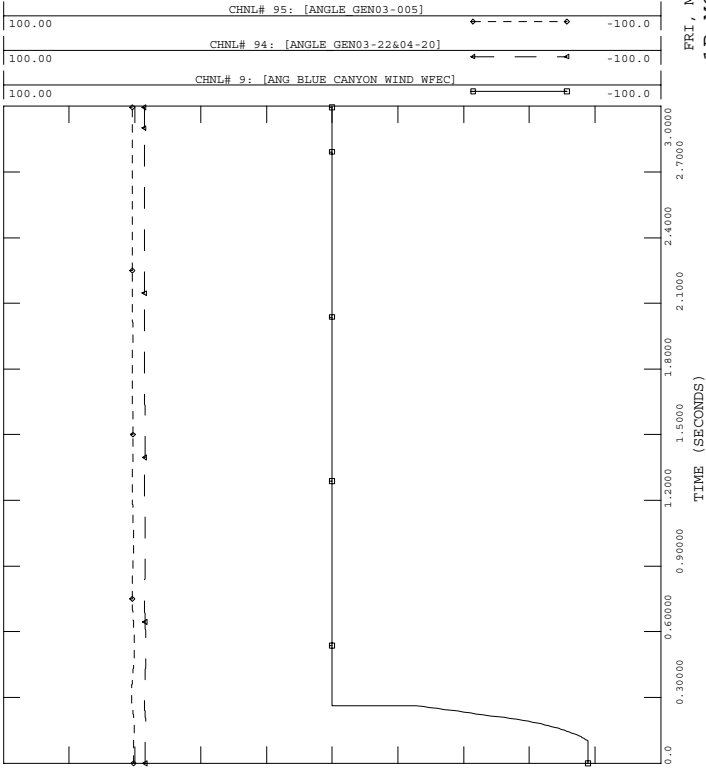

2004 SERIES, NERC/MMWG BASE CASE LIBRARY
 2006 SUMMER, FINAL; FOR DYN
 CASE1 : SUMMER PEAK
 STUDY PLANT (GEN04-023) & GEN03-005 IN-SERVICE
 FILE: Z:\common drive\sample plot\Casel-output\1_FLT13PH.OUT

FRI, MAY 13 2005 17:27
 1D-VOLTAGE @WIND MC

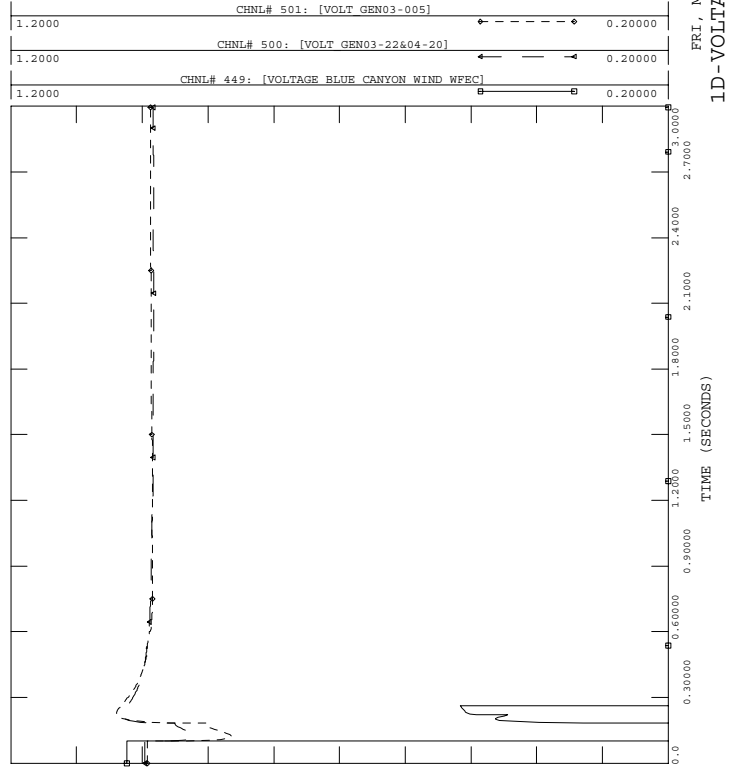

2004 SERIES, NERC/MMWG BASE CASE LIBRARY
 2006 SUMMER, FINAL; FOR DYN
 CASE1 : SUMMER PEAK
 STUDY PLANT (GEN04-023) & GEN03-005 IN-SERVICE
 FILE: Z:\common drive\sample plot\Casel-output\1_FLT13PH.OUT

FRI, MAY 13 2005 17:27
 1A-MC ANGLE WIND

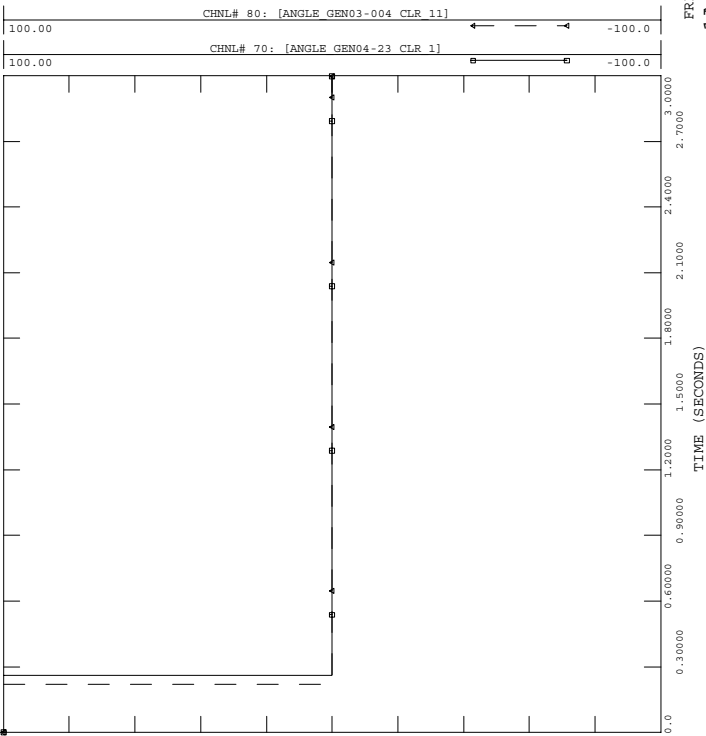

2004 SERIES, NERC/MMWG BASE CASE LIBRARY
 2006 SUMMER, FINAL; FOR DYN
 CASE1 : SUMMER PEAK
 STUDY PLANT (GEN04-023) & GEN03-005 IN-SERVICE
 FILE: Z:\common drive\sample plot\Casel-output\1_FLT13PH.OUT

FRI, MAY 13 2005 17:27
 1C-VOLTAGE @WIND MC

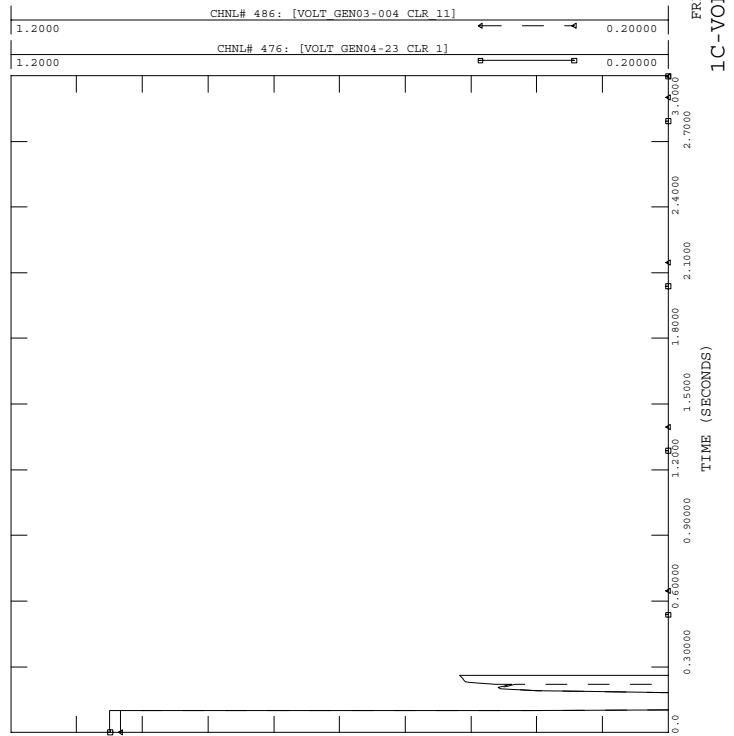



2004 SERIES, NERC/MMWG BASE CASE LIBRARY
 2006 SUMMER, FINAL; FOR DYN
 CASE1 : SUMMER PEAK
 STUDY PLANT (GEN04-023)& GEN03-005 IN-SERVICE
 FILE: Z:\common drive\sample plot\Casel-output\1_FLT13PH.OUT

FRI, MAY 13 2005 17:27
 2B-SPEED

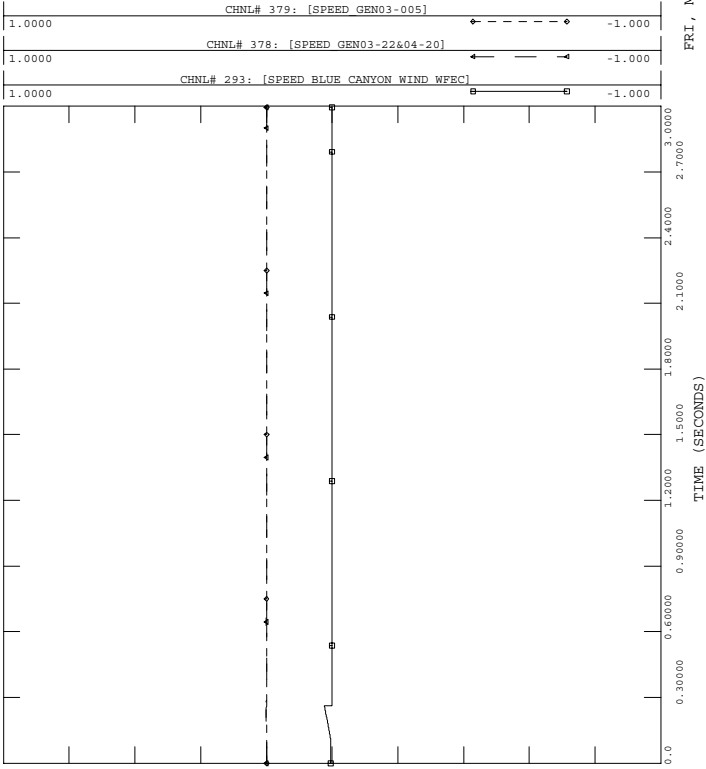

2004 SERIES, NERC/MMWG BASE CASE LIBRARY
 2006 SUMMER, FINAL; FOR DYN
 CASE1 : SUMMER PEAK
 STUDY PLANT (GEN04-023)& GEN03-005 IN-SERVICE
 FILE: Z:\common drive\sample plot\Casel-output\1_FLT13PH.OUT

FRI, MAY 13 2005 17:27
 2D-PELEC (MW)

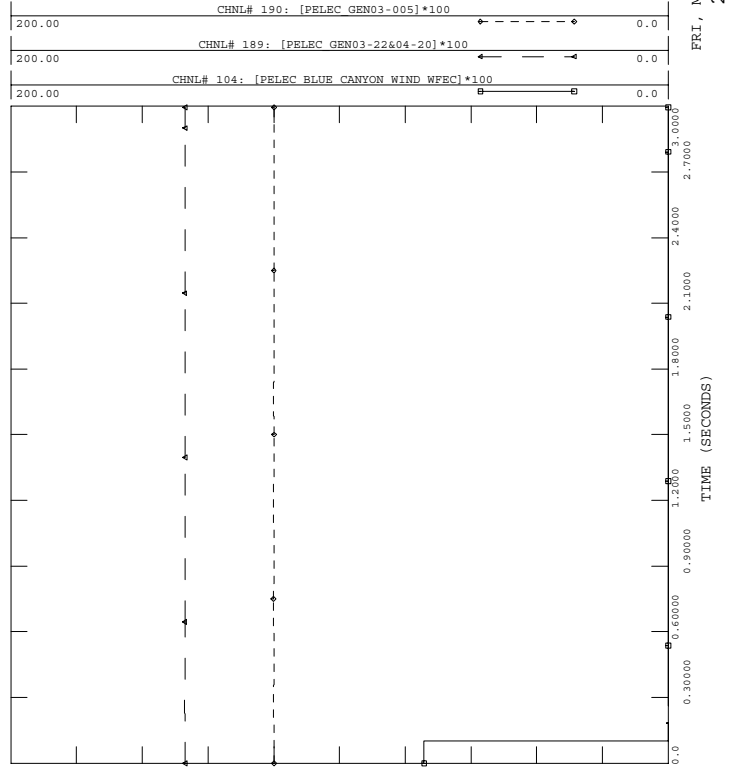

2004 SERIES, NERC/MMWG BASE CASE LIBRARY
 2006 SUMMER, FINAL; FOR DYN
 CASE1 : SUMMER PEAK
 STUDY PLANT (GEN04-023)& GEN03-005 IN-SERVICE
 FILE: Z:\common drive\sample plot\Casel-output\1_FLT13PH.OUT

FRI, MAY 13 2005 17:27
 2A-SPEED

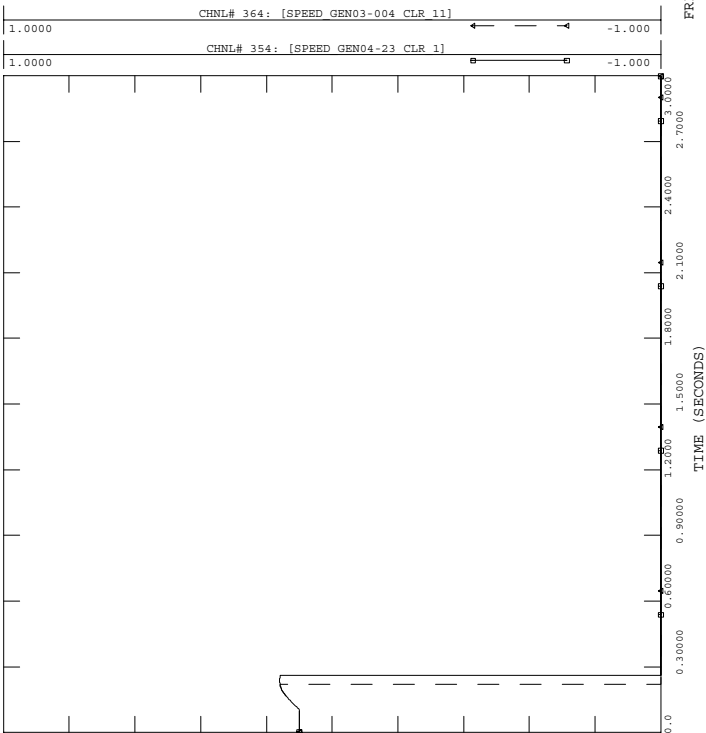

2004 SERIES, NERC/MMWG BASE CASE LIBRARY
 2006 SUMMER, FINAL; FOR DYN
 CASE1 : SUMMER PEAK
 STUDY PLANT (GEN04-023)& GEN03-005 IN-SERVICE
 FILE: Z:\common drive\sample plot\Casel-output\1_FLT13PH.OUT

FRI, MAY 13 2005 17:27
 2C-PELEC (MW)

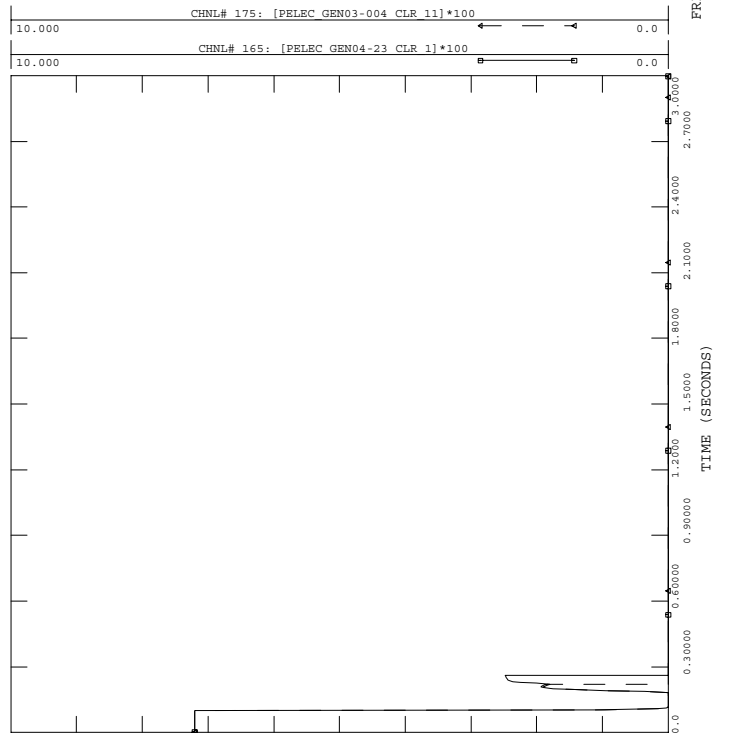



2004 SERIES, NERC/MMWG BASE CASE LIBRARY
 2006 SUMMER, FINAL; FOR DYN
 CASE1 : SUMMER PEAK
 STUDY PLANT (GEN04-023) & GEN03-005 IN-SERVICE
 FILE: Z:\common drive\sample plot\Casel-output\1_FLT13PH.OUT

FRI, MAY 13 2005 17:27
 3B-QELEC (MVAR)

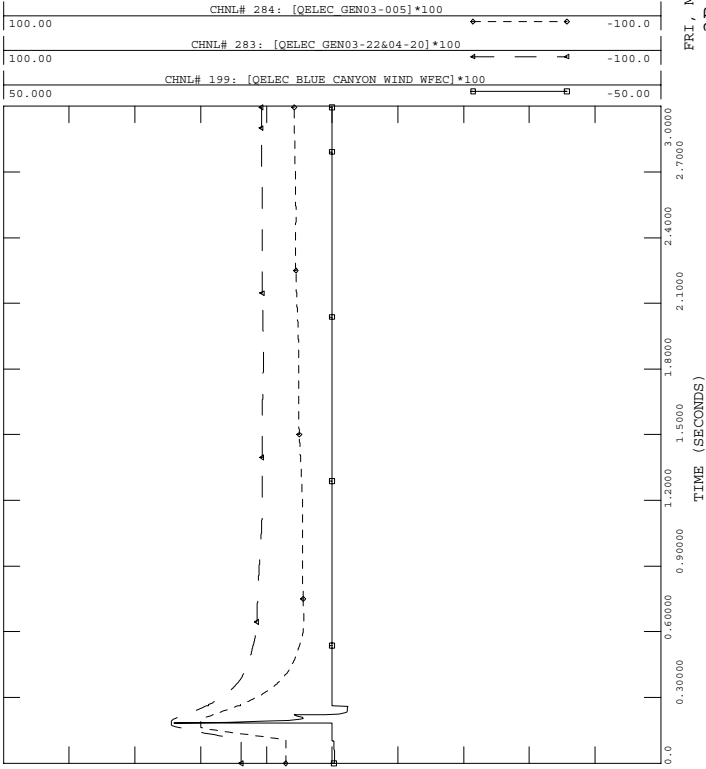

2004 SERIES, NERC/MMWG BASE CASE LIBRARY
 2006 SUMMER, FINAL; FOR DYN
 CASE1 : SUMMER PEAK
 STUDY PLANT (GEN04-023) & GEN03-005 IN-SERVICE
 FILE: Z:\common drive\sample plot\Casel-output\1_FLT13PH.OUT

FRI, MAY 13 2005 17:27
 3D-VOLTAGE-138KV

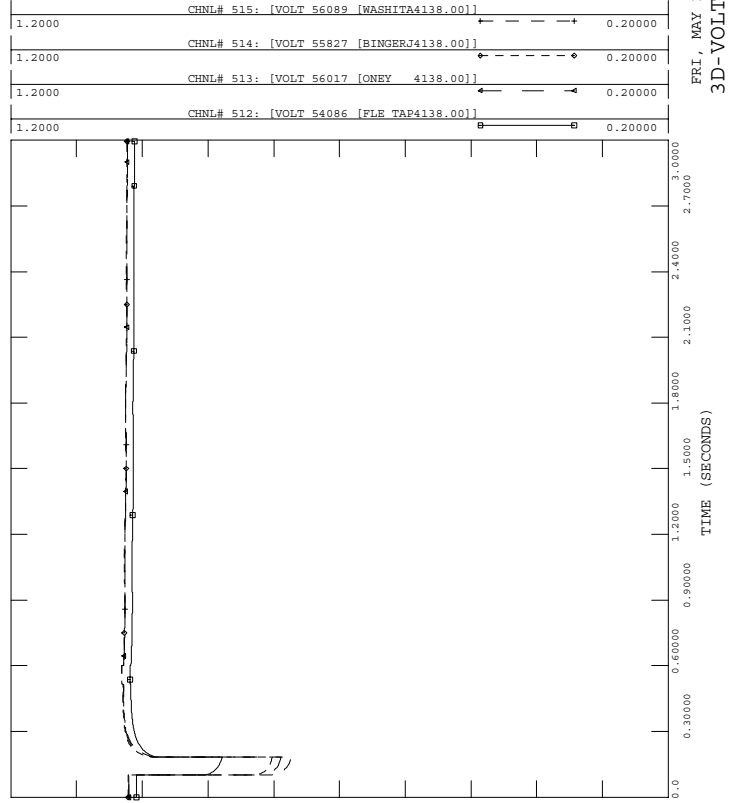

2004 SERIES, NERC/MMWG BASE CASE LIBRARY
 2006 SUMMER, FINAL; FOR DYN
 CASE1 : SUMMER PEAK
 STUDY PLANT (GEN04-023) & GEN03-005 IN-SERVICE
 FILE: Z:\common drive\sample plot\Casel-output\1_FLT13PH.OUT

FRI, MAY 13 2005 17:27
 3A-QELEC (MVAR)

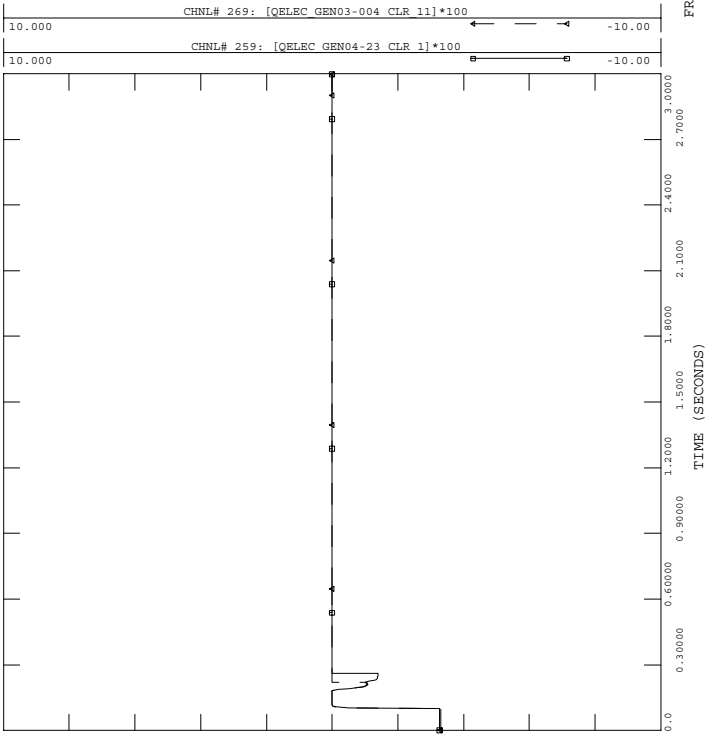

2004 SERIES, NERC/MMWG BASE CASE LIBRARY
 2006 SUMMER, FINAL; FOR DYN
 CASE1 : SUMMER PEAK
 STUDY PLANT (GEN04-023) & GEN03-005 IN-SERVICE
 FILE: Z:\common drive\sample plot\Casel-output\1_FLT13PH.OUT

FRI, MAY 13 2005 17:27
 3C-VOLTAGE-138KV

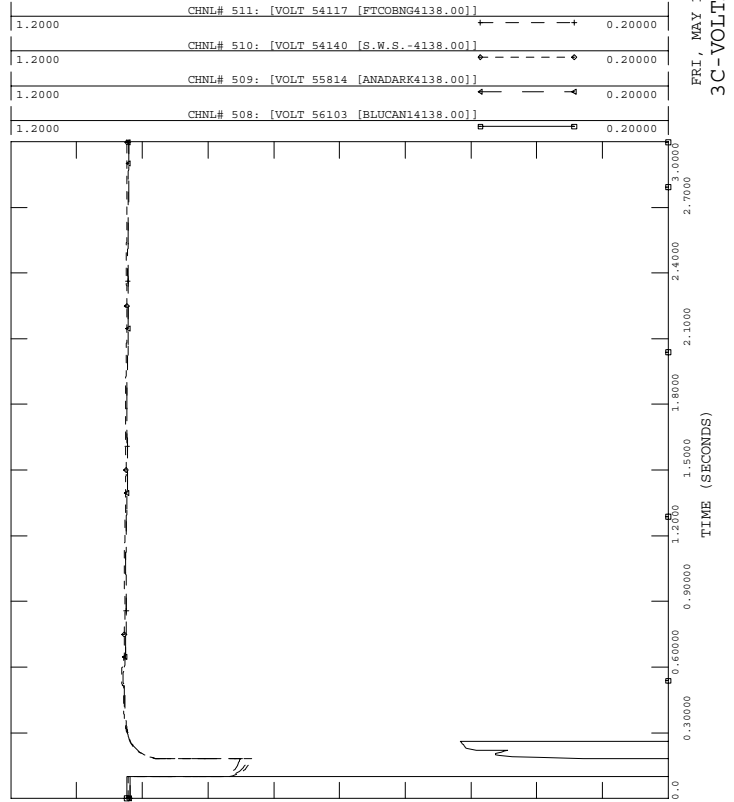



2004 SERIES, NERC/MMWG BASE CASE LIBRARY
 2006 SUMMER, FINAL; FOR DYN
 CASE2 : SUMMER PEAK. STUDY PLANT (GEN04-023) IN-SERVICE
 GEN03-005 OUT-OF-SERVICE

FILE: Z:\common drive\sample plot\Case2-output\output\6_FLT61PH.OUT

FRI, MAY 13 2005 17:55
 1B-MC ANGLE WIND

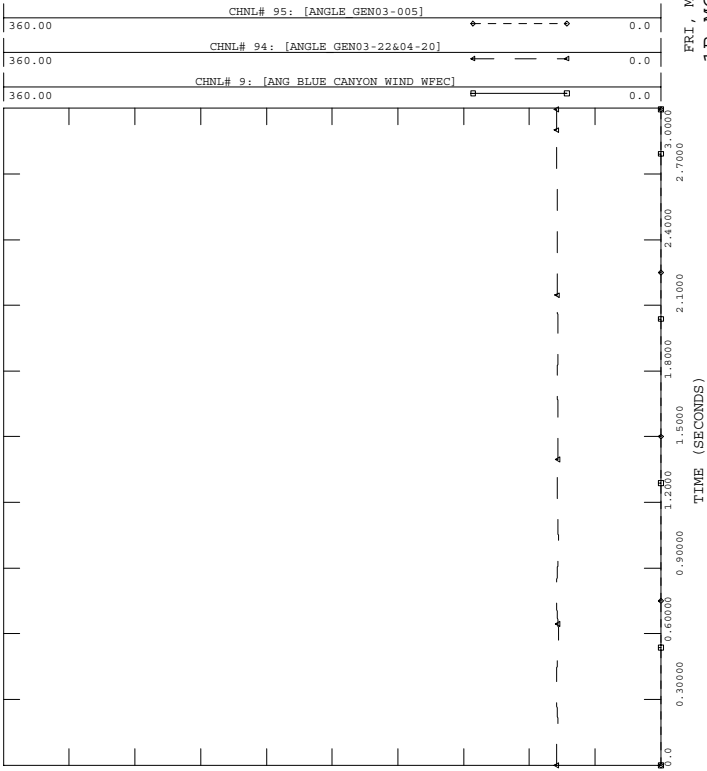

2004 SERIES, NERC/MMWG BASE CASE LIBRARY
 2006 SUMMER, FINAL; FOR DYN
 CASE2 : SUMMER PEAK. STUDY PLANT (GEN04-023) IN-SERVICE
 GEN03-005 OUT-OF-SERVICE

FILE: Z:\common drive\sample plot\Case2-output\output\6_FLT61PH.OUT

FRI, MAY 13 2005 17:55
 1D-VOLTAGE @WIND MC

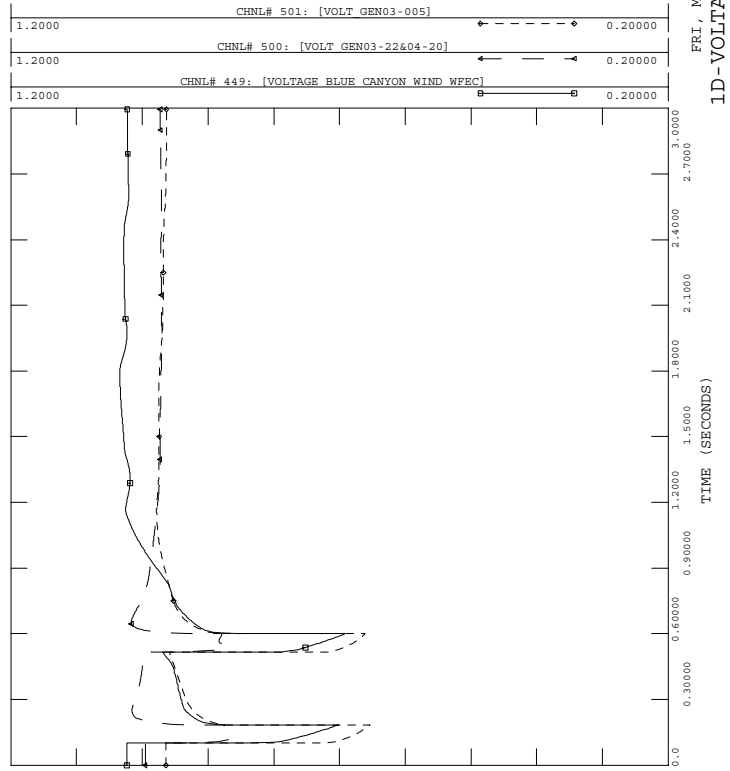

2004 SERIES, NERC/MMWG BASE CASE LIBRARY
 2006 SUMMER, FINAL; FOR DYN
 CASE2 : SUMMER PEAK. STUDY PLANT (GEN04-023) IN-SERVICE
 GEN03-005 OUT-OF-SERVICE

FILE: Z:\common drive\sample plot\Case2-output\output\6_FLT61PH.OUT

FRI, MAY 13 2005 17:55
 1A-MC ANGLE WIND

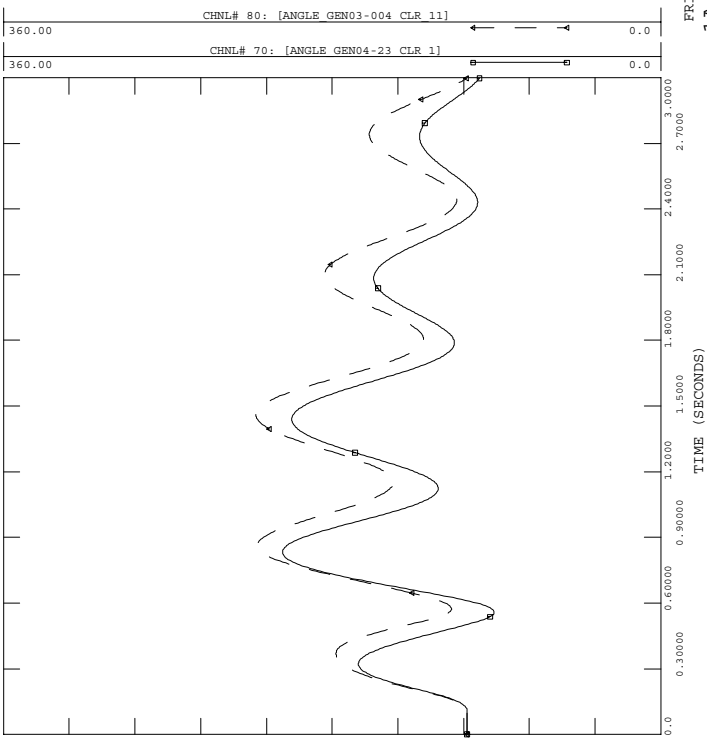

2004 SERIES, NERC/MMWG BASE CASE LIBRARY
 2006 SUMMER, FINAL; FOR DYN
 CASE2 : SUMMER PEAK. STUDY PLANT (GEN04-023) IN-SERVICE
 GEN03-005 OUT-OF-SERVICE

FILE: Z:\common drive\sample plot\Case2-output\output\6_FLT61PH.OUT

FRI, MAY 13 2005 17:55
 1C-VOLTAGE @WIND MC

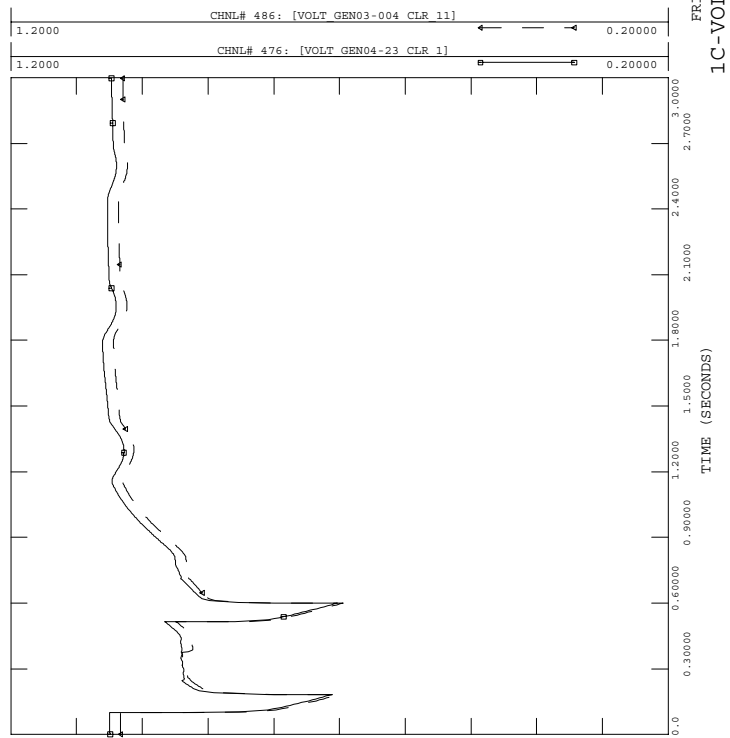



2004 SERIES, NERC/MMWG BASE CASE LIBRARY
 2006 SUMMER, FINAL; FOR DYN
 CASE2 : SUMMER PEAK. STUDY PLANT (GEN04-023) IN-SERVICE
 GEN03-005 OUT-OF-SERVICE

FILE: Z:\common drive\sample plot\Case2-output\output\6_FLT61PH.OUT

FRI, MAY 13 2005 17:55
 2B-SPEED

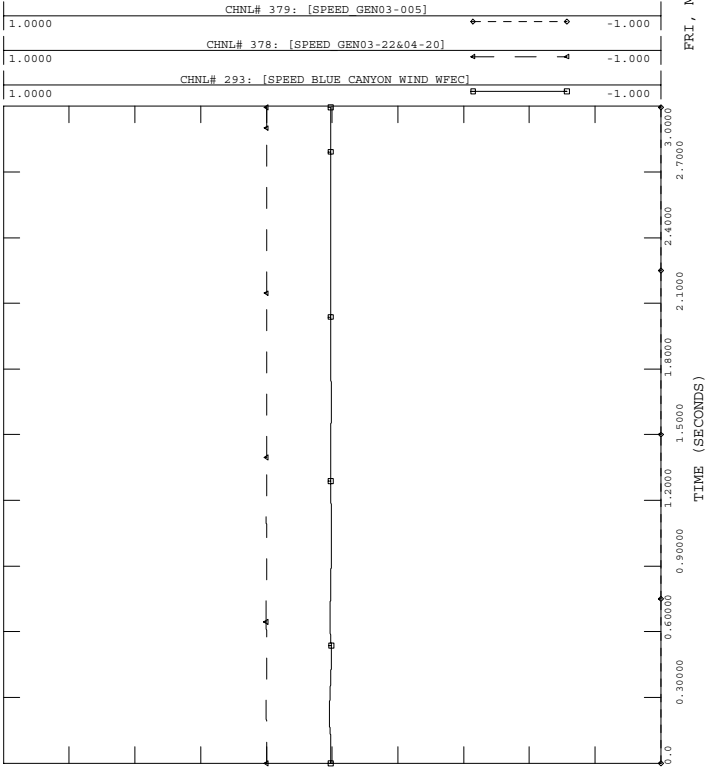

2004 SERIES, NERC/MMWG BASE CASE LIBRARY
 2006 SUMMER, FINAL; FOR DYN
 CASE2 : SUMMER PEAK. STUDY PLANT (GEN04-023) IN-SERVICE
 GEN03-005 OUT-OF-SERVICE

FILE: Z:\common drive\sample plot\Case2-output\output\6_FLT61PH.OUT

FRI, MAY 13 2005 17:55
 2D-PELEC (MW)

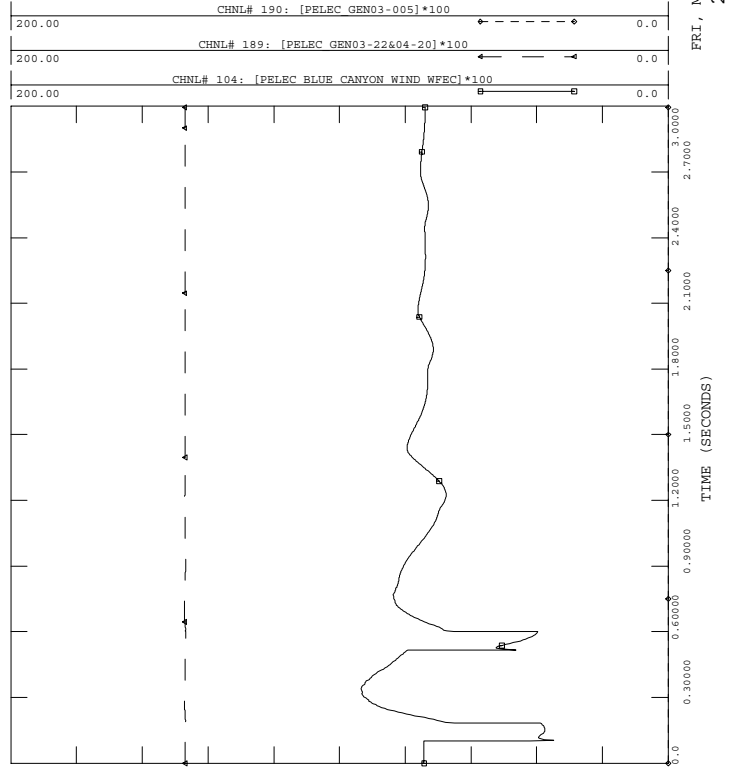

2004 SERIES, NERC/MMWG BASE CASE LIBRARY
 2006 SUMMER, FINAL; FOR DYN
 CASE2 : SUMMER PEAK. STUDY PLANT (GEN04-023) IN-SERVICE
 GEN03-005 OUT-OF-SERVICE

FILE: Z:\common drive\sample plot\Case2-output\output\6_FLT61PH.OUT

FRI, MAY 13 2005 17:55
 2A-SPEED

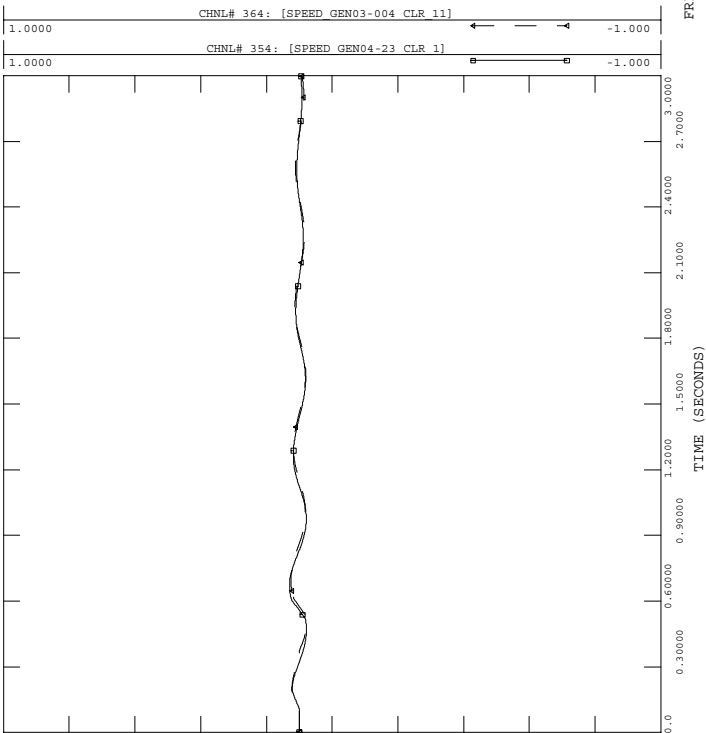

2004 SERIES, NERC/MMWG BASE CASE LIBRARY
 2006 SUMMER, FINAL; FOR DYN
 CASE2 : SUMMER PEAK. STUDY PLANT (GEN04-023) IN-SERVICE
 GEN03-005 OUT-OF-SERVICE

FILE: Z:\common drive\sample plot\Case2-output\output\6_FLT61PH.OUT

FRI, MAY 13 2005 17:55
 2C-PELEC (MW)

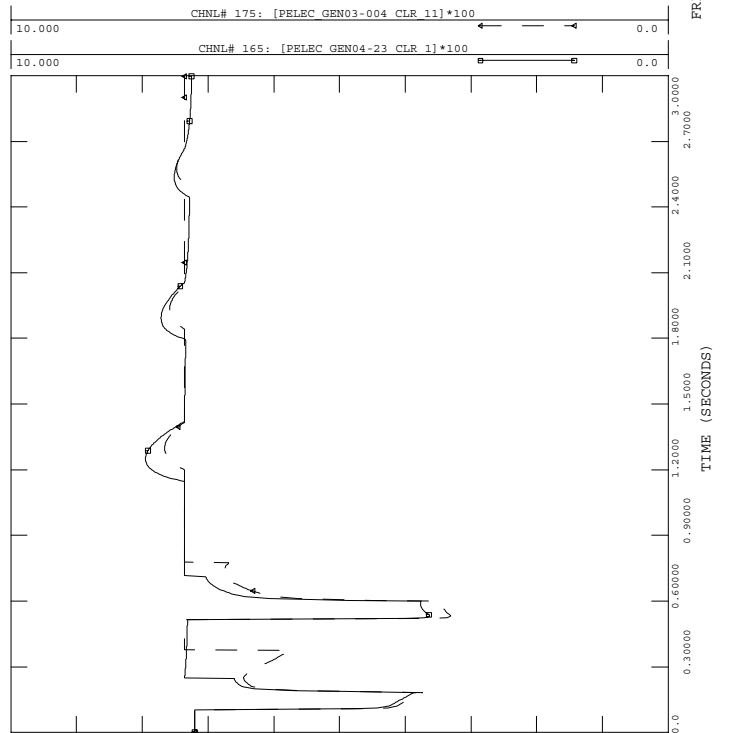



2004 SERIES, NERC/MMWG BASE CASE LIBRARY
 2006 SUMMER, FINAL; FOR DYN
 CASE2 : SUMMER PEAK. STUDY PLANT (GEN04-023) IN-SERVICE
 GEN03-005 OUT-OF-SERVICE
 FILE: Z:\common drive\sample plot\Case2-output\output\6_FLT61PH.OUT

FRI, MAY 13 2005 17:55
 3B-QELEC (MVAR)

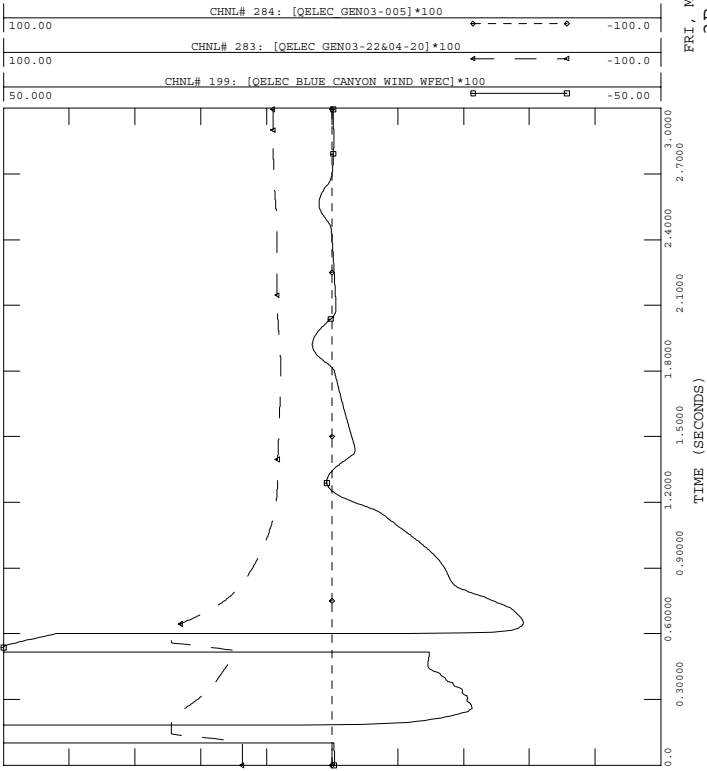

2004 SERIES, NERC/MMWG BASE CASE LIBRARY
 2006 SUMMER, FINAL; FOR DYN
 CASE2 : SUMMER PEAK. STUDY PLANT (GEN04-023) IN-SERVICE
 GEN03-005 OUT-OF-SERVICE
 FILE: Z:\common drive\sample plot\Case2-output\output\6_FLT61PH.OUT

FRI, MAY 13 2005 17:55
 3D-VOLTAGE-138KV

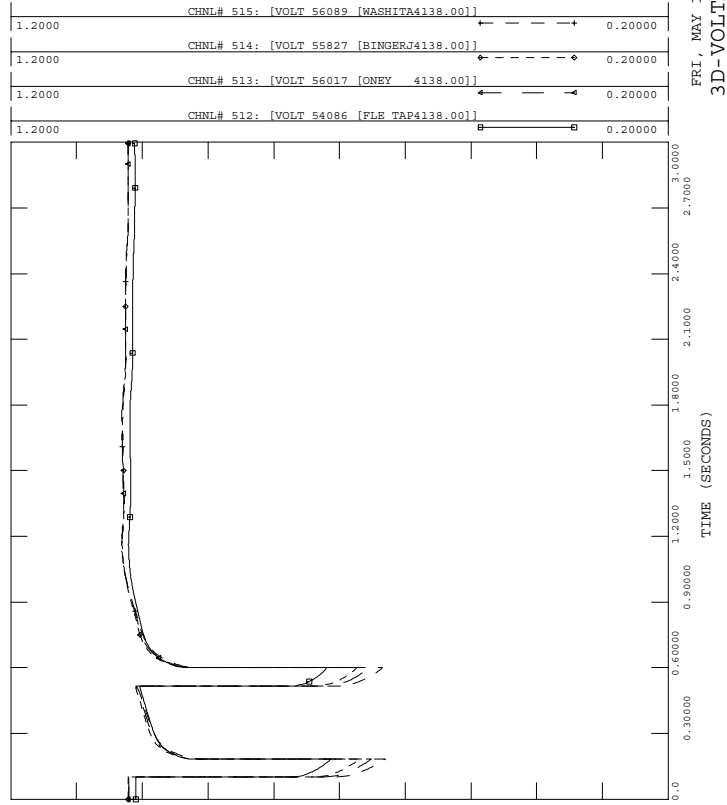

2004 SERIES, NERC/MMWG BASE CASE LIBRARY
 2006 SUMMER, FINAL; FOR DYN
 CASE2 : SUMMER PEAK. STUDY PLANT (GEN04-023) IN-SERVICE
 GEN03-005 OUT-OF-SERVICE
 FILE: Z:\common drive\sample plot\Case2-output\output\6_FLT61PH.OUT

FRI, MAY 13 2005 17:55
 3A-QELEC (MVAR)

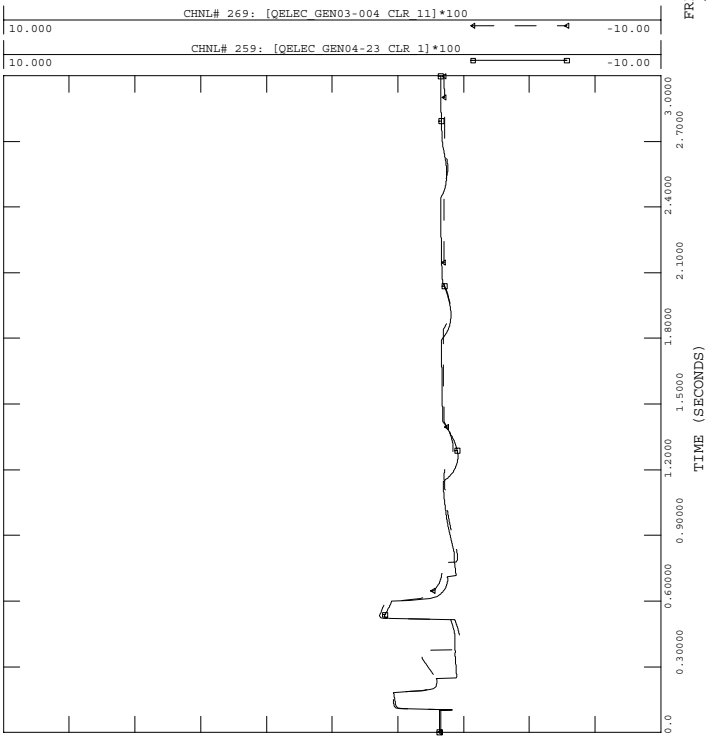

2004 SERIES, NERC/MMWG BASE CASE LIBRARY
 2006 SUMMER, FINAL; FOR DYN
 CASE2 : SUMMER PEAK. STUDY PLANT (GEN04-023) IN-SERVICE
 GEN03-005 OUT-OF-SERVICE
 FILE: Z:\common drive\sample plot\Case2-output\output\6_FLT61PH.OUT

FRI, MAY 13 2005 17:55
 3C-VOLTAGE-138KV

